

NIVOMAT FS 21 Fill-Level Probe

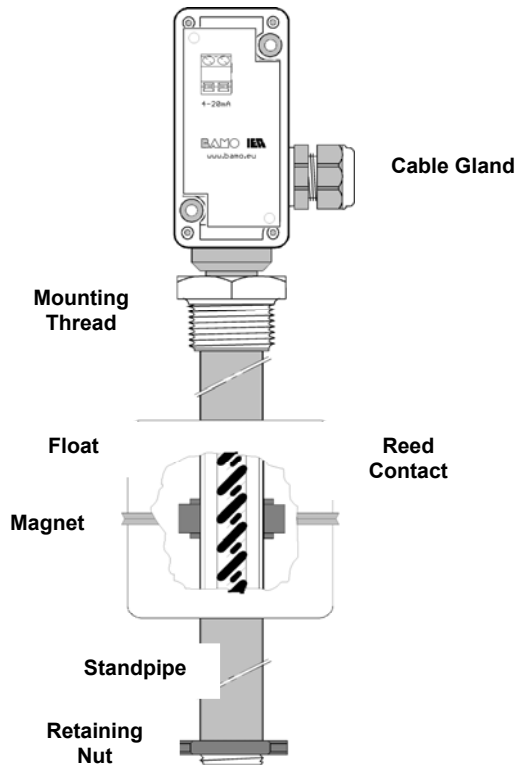

Safety Precautions

- The device may only be connected to supply power which is rated as specified in the technical data!
- Installation, initial start-up and maintenance may only be performed by trained personnel!

Functions Description

The NIVOMAT® FS 21.. fill-level probe functions on the basis of a float with attached magnet, which is guided up and down a vertical standpipe. Changes to the fill-level cause the float to move in the vertical direction. The magnet switches monostable reed contacts which are equipped with resistors and mounted inside the standpipe. This results in a series of resistances which is analogous to the fill-level. Based on the change in resistance, the measuring transducer generates a 4 to 20 mA signal.

NIVOMAT FS 21 probes are equipped with a 4 to 20 mA output and can be connected to the following devices:

- Analogue input at a PLC
- Switching amplifier
- Other commercially available devices which indicate 0 to 100% and have a 4 to 20 mA input

Use for Intended Purpose

The NIVOMAT® FS 21.. fill-level probe is used as a measuring sensor for semi-continuous fill-level indication in tanks with liquid content, for example:

- Industrial water, coolant water, acids or lye
- Oils and fuels
- Condensate
- Chemicals
- Electroplating baths

Resistance of the float and standpipe materials to the respective medium must be taken into consideration.

Use only with low viscosity media with minimal solid content which do not tend to become sticky or gummy, or to crystallise. Any solid content must be non-magnetic.

Storage

FS probes with standpipes made of plastic must be stored such that no bending can occur. If necessary, the float must be dismantled.

Installation

The fill-level probe is secured by means of a flange or threaded connection which is suitable for the standpipe.

Installation procedure:

- Unscrew the retaining nut from the bottom end of the standpipe.
- Remove the float.
- Insert the standpipe through the opening in the respective tank.
- Slide the float onto the standpipe with the "Top" symbol pointing up.
- Screw the nut back onto the standpipe. In the case of the stainless steel variant, don't forget the disc-spring washer.

Do not fail to observe the following!

- Install vertically only.
- The float must not come into contact with the wall of the tank or any other built-in components.
- Do not bend the standpipe either during installation or operation.
In the case of powerful transverse flow currents (e.g. caused by mixers), install a flap, a protective panel, a guide or similar apparatus inside the tank.
- Protect the probe from severe impacts and shocks.
- Maintain a distance of at least 10 cm from the sides of the probe to any steel objects.

Electrical Connection

- Use shielded cables with a cross-section of at least 0.5 square mm.
- Maximum cable length depends upon external load impedance (see diagram below).

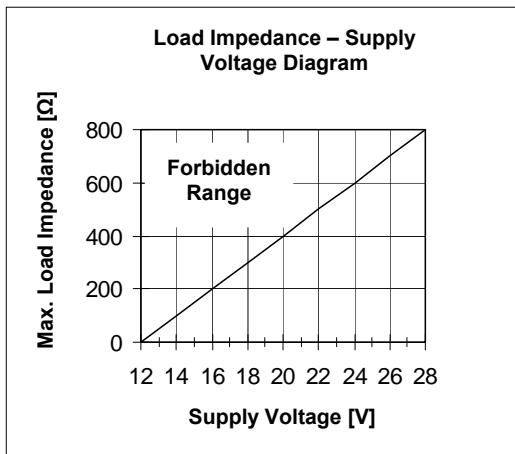

Load impedance is the sum of the resistance values for the interconnected devices **and** utilised connector cables.

The signal line can be connected to the FS probe without any regard to correct polarity.

However, correct polarity is required when connecting the measuring instrument / PLC input.

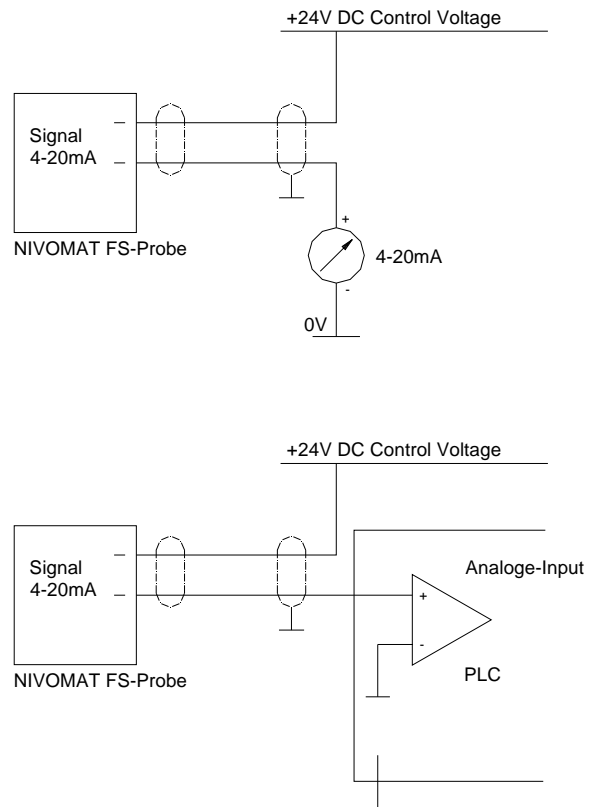

Initial Start-Up

Before initial start-up, the NIVOMAT® FS 21.. should be tested with an ammeter to make sure that it generates an output current of 4 to 20 mA. The float is moved slowly along the guide tube to this end.

Technical Data

Standpipe material	1.4571 stainless steel		PVC	PE	PP	PVDF
Float material	1.4571 stainless steel		PP	PP		PVDF
Float diameter	92.5	52.5	52.5	78		78
Float length	110	70	50	70		70
Minimum density of the liquid medium	0.75	0.85	0.85	0.85		0.85
Resolution FS 21	10 mm					
Supply power	12 to 28 V DC					
Output current	4 ... 20 mA					
Ambient temperature	-20 to +60° C					
Max. viscosity	90 to 100 cSt					
Max. operating pressure	25 bar	2 bar	2 bar			
Mounting thread	G 1/2"		G 1"			G 3/4"
Medium temperature *	-20 to +90° C	0 to +60° C	+5 to +60° C	0 to +60° C		-5 to +80° C
Terminal housing	Polycarbonate, IP 65					
Cable gland	Polyamide, M16x1,5					

* Depends upon chemical resistance, see resistance tables provided by materials manufacturers

Dimensions

Stainless Steel	PE / PP / PVDF