

SKV adjustable Float Switch Combination



Safety Precautions

- Installation, initial start-up and maintenance work may only be performed by trained personnel!



- Ground metal containers, or use safety extra-low voltage or KSR contact protection relay!

Function Description

SKV... float switch combinations represent a simple, flexible method for the realisation of several switching points. The switches are attached to the tube with clamps at the desired switching points. The clamps can be positioned as desired within the specified range. The G2" threaded connector allows for implementation of up to 5 switching points.

Caution!

Not suitable for installation to containers with mixers, strong media current or turbulent flow!



IER Meß- und Regeltechnik
Eberhard Henkel GmbH
 Innstrasse 2
 68199 Mannheim

Tel.+49 (0)621 84224-0 • Fax:+49 (0)621 84224-90
 e-Mail: info@IER.de • Internet: www.IER.de

Technical Data

Materials:

Float and fitting: polyethylene (PE-HD), fitting and tube: PVC, IP 68 protection

Clamps:

Polypropylene (PP)

Terminal housing:

Fibre-glass reinforced PBT, IP 65

Cable:

See type key

Switching element:

Potential-free micro-switch, changeover contact (combination gold contact)

Installation and switching angle:

The float actuated switch is secured to a fixed point on a vertical PVC-pipe. The float monitors the fill-level. The integrated contacts switch at an angle of approx. 5°/15° above or below the fixed point.

The exact switch point depends on the length of the cable between fix point and float switch and on the velocity of the change of the fill level.

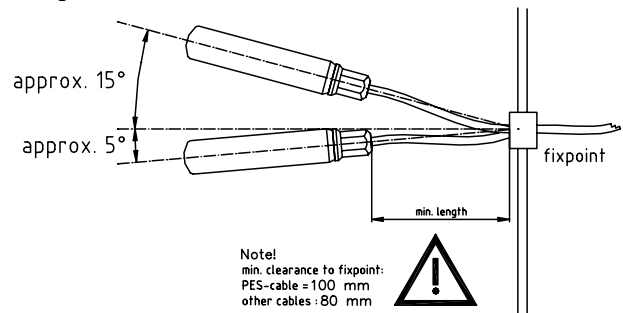

Switching voltage:

4 V to 250 V AC, 4 to 30 V DC

Switching current:

1 mA to 3 A

Operating temperature:

+1 to +60° C

Max. length:

2000 mm

Max. operating pressure:

0.5 bar

Media Density

Cable Type 1,2,4,5,6: $\rho \geq 1 \text{ g/cm}^3$

Cable Type 3 (oil resist): $\rho \geq 0,9 \text{ g/cm}^3$

Cable, resistance to chemicals:

TPK – water, lye, weak acids

PES – acid resistant

PVC – oil resistant

CE Mark:

In accordance with low-voltage directive (73/23/EWG), EMC directives (89/336/EEC)

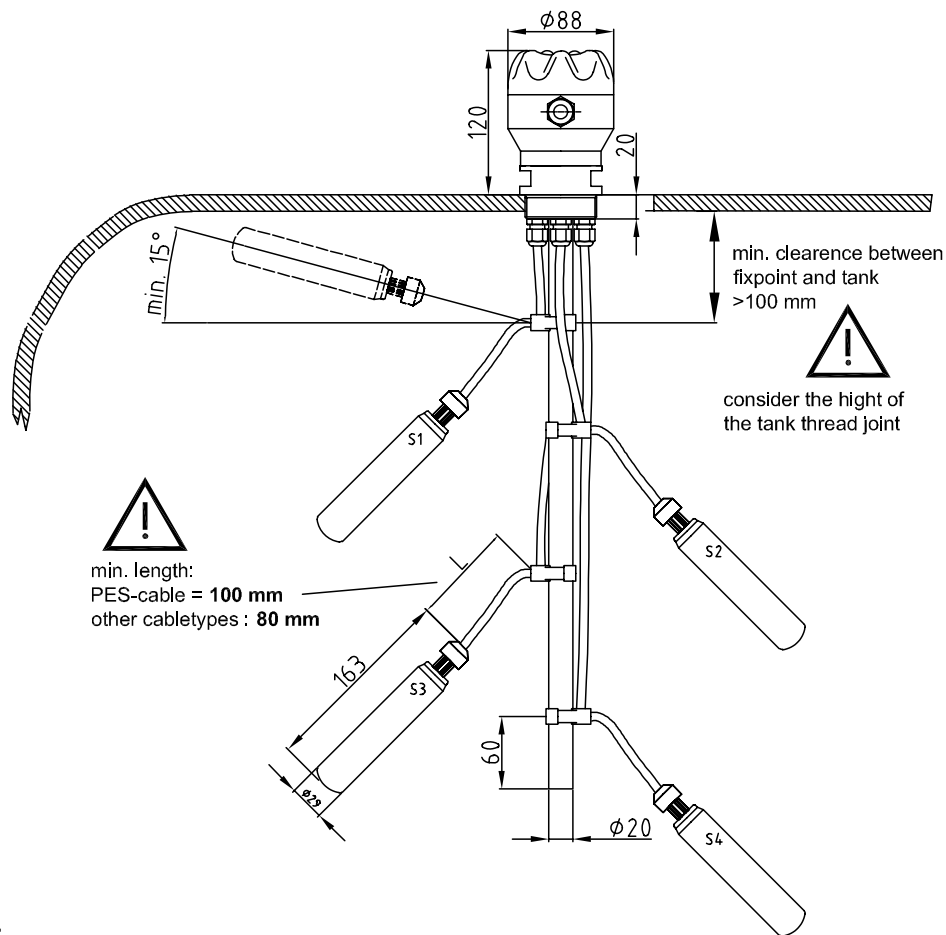

Dimensions:

Float Switch-Combination SKV 4 ...

Mounting:

- always mount vertically
- floats must be able to move freely
- floats should not stumble against the wall

Adjustment of Switching point

- move the clamps by hand
- Consider the switching angle
- Approximately 50 mm of extra cable is provided in the terminal housing for each switching point to allow for downward adjustment.
- loosen the compression gland
- pull the cable down
- then retighten the cable gland.

EI. Connection

contacts are shown at "float is down"

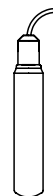

	1st. Switch	2nd. Switch	3rd. Switch	4th. Switch	5th. Switch	6th. Switch	
	3	6	9	12	15	18	Terminal-No.
	2	5	8	11	14	17	
	1	4	7	10	13	16	

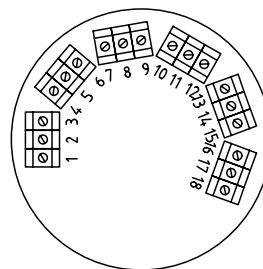

Note:
the first switch is always the top float of the SKV